



# Operating instructions

(Translation of the original operating instructions)

## OctaVent



## Table of contents

<b>1. General</b>	<b>4</b>
<b>2. Description of the system elements</b>	<b>5</b>
2.1. Illustration of the system elements	5
2.2. Functionality of the system	7
2.3. Intended use	7
2.4. Residual risk	7
<b>3. Safety instructions</b>	<b>8</b>
3.1. Definition of the hazard symbols	8
3.2. General safety instructions	8
<b>4. Storage, transport and installation of the device</b>	<b>10</b>
<b>5. Commissioning</b>	<b>12</b>
5.1. Electrical connection	13
5.2. Coating of the filter cartridges with cartridge protection	13
5.3. Connecting the compressed air supply	14
5.3.1. Compressed air supply for the cleaning of the filter cartridges	14
<b>6. Operating the system</b>	<b>15</b>
6.1. Explanation of the operating elements	15
6.2. Connection of an external control	16
6.3. Access to the OctaVent through external end devices	16
6.4. Connecting to the OctaVents's WiFi	17
<b>7. Maintenance</b>	<b>18</b>
7.1. Reset to maintenance state	19
7.2. Cleaning the filter cartridges	19
7.3. Replacing the filter unit	20
7.4. Replacing the filter cartridges	25
7.5. Checking the fill level or replacing the disposable dust collecting tank	32
7.6. Draining the condensate	33
7.7. Replacing the activated carbon filter mats	34
7.8. Replacing the filter mats for the air outlet grille	35
7.9. Changing the air quality sensor	36
7.10. Coating of new filter cartridges with cartridge protection	37
<b>8. Dismantling / Disposal</b>	<b>38</b>
<b>9. Diagnostics and troubleshooting</b>	<b>38</b>
<b>10. List of spare parts</b>	<b>40</b>
<b>11. Technical data</b>	<b>41</b>
<b>12. EC declaration of conformity</b>	<b>42</b>
<b>13. Training protocol</b>	<b>43</b>
<b>14. Maintenance intervals</b>	<b>44</b>
14.1. Usage-related maintenance	44
14.2. General maintenance	45

---

14.2.1. Visual inspection of the device	45
14.2.2. Visual inspection of the pneumatic pipes	46
14.2.3. Functional test of the device	46
14.2.4. Electrical test of the electrical lines and earthing connections	47

## 1. General

Congratulations on purchasing the product from TEKA.

Our engineers ensure that our devices reflect the state of the art through continuous development. Nevertheless, misuse or misconduct can endanger your safety. Please observe the following for a successful use of the device:



Only authorised and instructed personnel can carry out transport, operation, maintenance and repair of the device. The operator must ensure that the operating personnel take note of these instructions.

Please read these instructions before operating the device, and observe the safety precautions to avoid injury!

Store this manual in a safe place! These instructions are to be regarded as a component of the product!

Adhere to all product notes!

Modifications or conversions that the operator carries out at the device without the consent of the manufacturer, can lead to new safety hazards or to the loss of warranty claims.

Observe the manufacturer's instructions. Contact the manufacturer in case of any uncertainty:

Tel: +49 2541-84841-0

E-mail: [info@teka.eu](mailto:info@teka.eu)

## 2. Description of the system elements

### 2.1. Illustration of the system elements

Installation example:

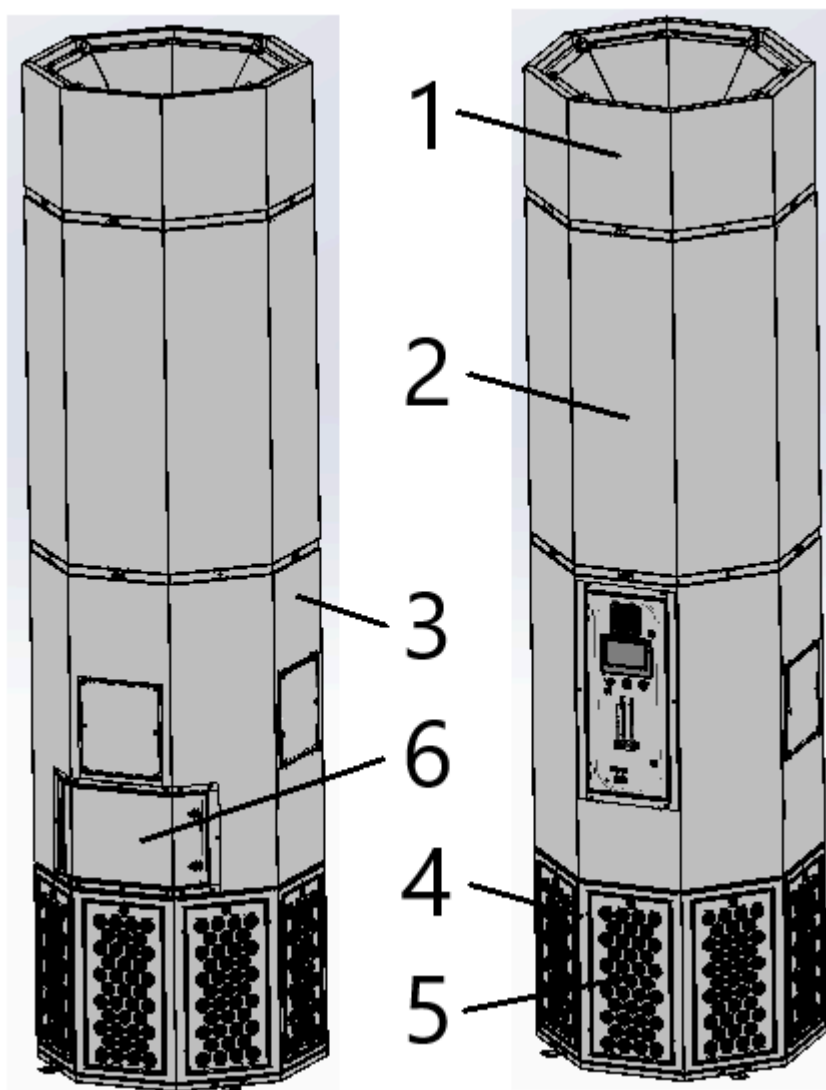

Z.Nr. 25088945

Pos.1	Suction housing
Pos.2	Filter unit (Filter housing including 4 filter cartridges)
Pos.3	Dust collecting housing / Cleaning housing
Pos.4	Fan housing
Pos.5	Exhaust grille with activated carbon filter mats
Pos.6	Service door for disposable dust collecting tank

# The Air Cleaners



open service door disposable dust collecting tank:

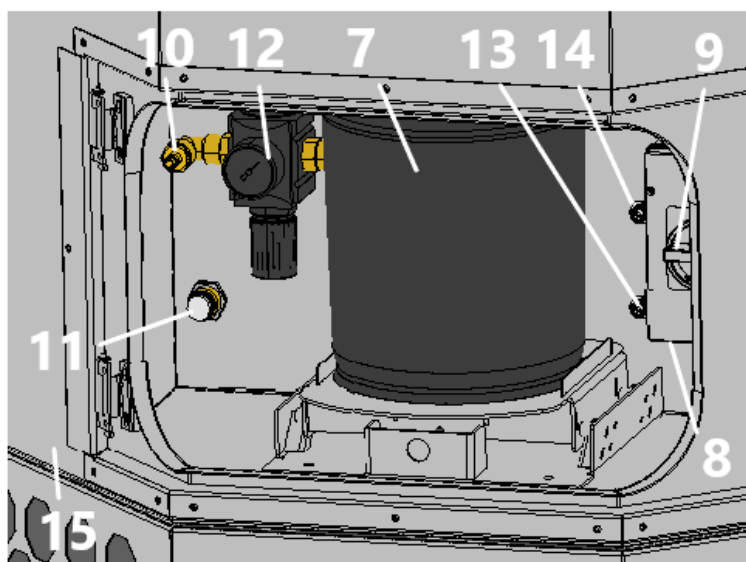

Operating elements:

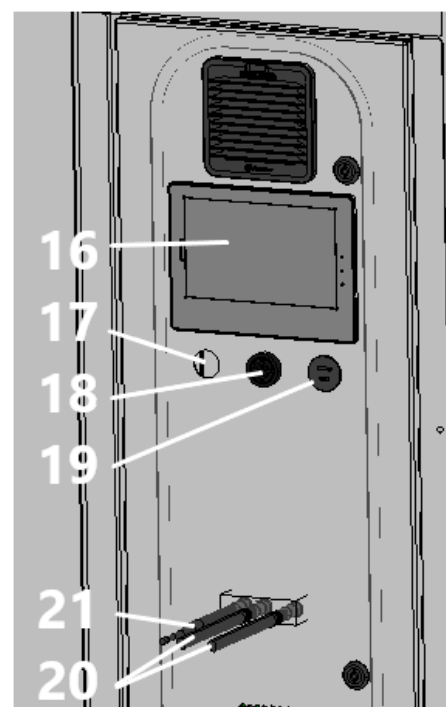

Pos.7	Disposable dust collecting tank	Pos.16	Operating panel of the control
Pos.8	Mains cable with plug	Pos.17	RJ45 port
Pos.9	Main switch	Pos.18	Signal horn
Pos.10	Connection for compressed air	Pos.19	USB-C / USB-A ports
Pos.11	Drain valve for compressed air	Pos.20	2 antennas for mobile communication
Pos.12	Pressure reducer	Pos.21	Antenna for Wi-Fi
Pos.13	Connection for external control unit (Start/Stop)		
Pos.14	Modbus interface for optional accessories		
Pos.15	Through hole for cables and hoses		

## 2.2. Functionality of the system

The filter unit serves to suck off and filter polluted air (according to the intended use). The air is purified on the surface of the filter cartridge in the filter section of the unit. The separated dust is collected in a dust collecting tank. The activated carbon filter absorbs gases and unpleasant odours. An automatic filter monitoring indicates when a cleaning or a replacement of the filters is necessary. The purified air is led back into the working room via an exhaust air grille.

## 2.3. Intended use

The device is intended for commercial use. If the device is made publicly accessible, it must never be operated unsupervised by authorized personnel, authorized by the operator.

The system is a room air extraction and filtering system. Fields of application are predominantly industrial enterprises, weld shops to handle e.g. dusts, post weld smoke. In addition, the system can supplement selective extraction systems.

<b>WARNING</b>	
	<p><b>Improper use can damage parts and be a danger to life and limb!</b></p> <p>The device must not be used for the extraction of oil-laden welding fume, explosive dust and gases, hybrid mixtures, glowing or burning substances, gases, water, etc. The device must not be operated in explosive zones.</p> <p>During welding work, the operating company must take measures with regard to ventilation and select them in a manner that ensures the protection of the welder and other employees. Hazardous materials should primarily be collected in their area of origin (source TRGS 528, 4.3). Collection in the area of origin is mandatory when processing stainless steels. The measures regulated in TRGS 528 mainly refer to respiratory protection and compliance with the occupational exposure limits (OEL). Personal protective measures in this regard are in particular regulated in clause 4.7 of TRGS 528.</p> <p>An important point to consider is that in order to comply with the occupational exposure limits (OEL), the employer must provide single workplace extraction units and personal protective measures in addition to the air handling system offered here.</p> <hr/> <p><b>Dangers arising from fire.</b></p> <p>If the sucked medium is combustible fume or dust, the operator must determine beforehand which fire protection measures are to be taken.</p>

## 2.4. Residual risk

<b>CAUTION</b>	
	<p><b>Danger due to possible hazardous materials in the exhaust air flow.</b></p> <p>Because the unit does not monitor the quality of the air in the exhaust air flow, we recommend that you always guide the exhaust air flow exiting our unit to areas (e.g. to the outside into the open air) in which there is no danger to any living being. To do this, it is necessary to fit a suitable exhaust air line at the filter unit.</p>

## 3. Safety instructions

### 3.1. Definition of the hazard symbols

The device is constructed according to the state of the art and the recognised safety regulations. Nevertheless, during use threats to life and limb of the user or other persons may arise. The impairment of the machine or other property are also possible. In these instructions we warn by using corresponding indications.

	<b>WARNING</b> <b>WARNING</b> These instructions are made in case of risks that can lead to <u>injury or death</u> .
---	--

	<b>CAUTION</b> <b>CAUTION</b> These instructions are made in case of risks that can lead to <u>injury</u> .
---	---

	<b>NOTICE</b> <b>NOTICE</b> These instructions are made in case of risks that can lead to <u>material damages</u> .
--	---

	Information notes are no hazard warnings; they call attention to useful information.
---	--

### 3.2. General safety instructions

	<b>WARNING</b> <b>Dangers arising from improper use / unauthorised operations.</b> The operator must ensure that their authorised personnel are familiar with all the safety indications in this manual in advance. The operator is responsible for ensuring that all work is carried out by authorised and qualified personnel. We therefore recommend using the training protocol on the last page for that purpose (see chapter "Training protocol"). Laymen are allowed to operate the device after having received the necessary instructions. But they are not allowed to carry out any installation, repair or maintenance work. <hr/> <b>Dangers arising from fire.</b> In case of fire, if possible, switch the unit immediately off or disconnect it from the power supply. Fire extinguishing measures which the operator is obliged to determine beforehand must be initiated immediately.
---	---



## WARNING

### **Dangers arising from electricity.**

The operator must ensure that electrical plants and equipment are only built, modified and maintained by a qualified electrician or under the direction and supervision of a qualified electrician. Do not work on components if you are not sure that these are disconnected. If necessary, disconnect the device from the electric power supply and secure it against unauthorized restarting.

## 4. Storage, transport and installation of the device

WARNING



**Risk of injury from tilting or unmounted components when stored or transported.**  
The device must be secured against tilting and slipping when it is stored or transported. Do not stand under or next to the floating load. Lift trucks, forklift trucks and transport cranes must have a sufficient minimum load bearing capacity.

---

**Dangers arising from tilting or functional impairments at its destination.**  
The unit may only be set up on a suitable surface. The unit may only be set up on a suitable surface. The surface must be vibration-free and horizontal. The operator must check the bearing capacity of the surface. The unit must be secured on the surface, for example using lag bolts or heavy-duty anchors.  
Use the 4 screw-on brackets at the system base.

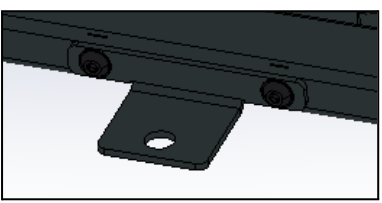

4x

---

**The main components must only be assembled after transport. Otherwise, there is a risk of damage during transport.**  
Prior to transporting the system, check that the main components (see illustration) are not assembled together. If the filter system has to be transported again after assembly, the main components have to be disassembled from each other.  
A forklift bracket is available as an alternative (item 95202006); this raises the system by 100 mm.

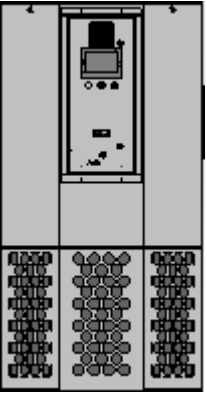

Lower part

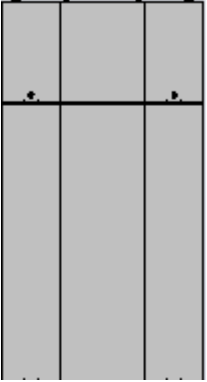

Upper part

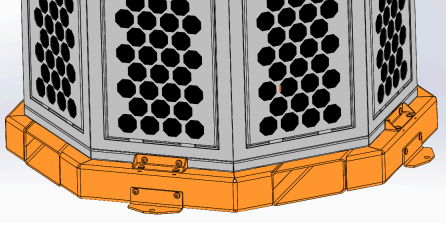

Forklift bracket

NOTICE



**Damage or functional impairment of the unit due to climatic influences.**  
The unit must be stored in a dry place and protected against moisture during transport. As a matter of principle, the filter unit is not designed to be installed outside.

- The system is delivered in 2 parts, upper part and lower part. First of all, the lower part must be transported to its destination and positioned at its precise designated position. Use the 4 lifting rings for this purpose.

**NOTICE** At least 0.8 metres of space must be left around the system. When the unit is assembled, there must be at least 1 metre of space between system and ceiling.

**WARNING** Use appropriate lifting tools (forklift truck, transport crane,...) with a minimum load-carrying capacity of 500 kg. The filter unit must be secured against tilting and slipping when it is moved, lifted or put down. No one is allowed to stand under or beside the load. Use only appropriate ladder tools.

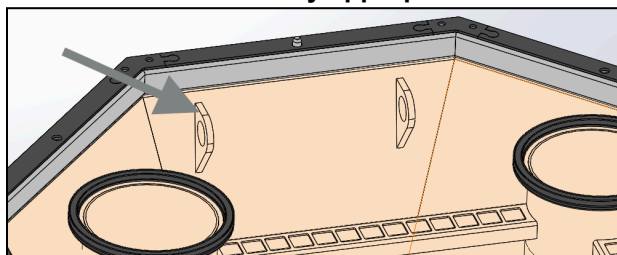

- Now check whether the seal at the lower part and the sealing surface of the upper part are clean and undamaged.
- Dismantle the 4 panels of the lower part by releasing the M6x12 rounded head screws. Keep the panels and screws in a safe place for later reassembly.

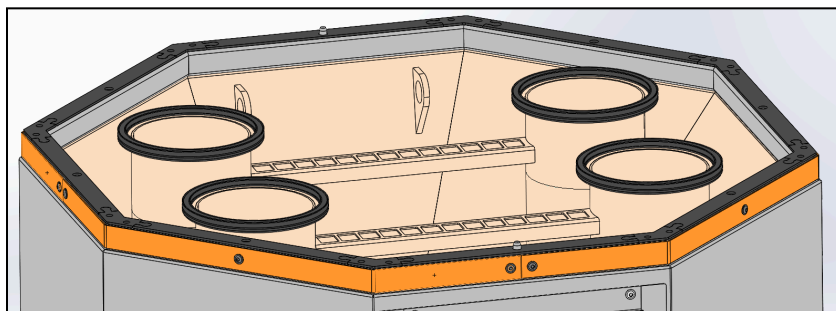

- Now lift the upper part onto the lower part. Use the 4 lifting rings to do so. At the same time, align the upper part so that the 2 mounting holes are located above the 2 guide pins of the lower part and can be inserted into each other.

**WARNING** The lifting rings must only be used for lifting the upper part. The lifting rings are not suited to lift the weight of the entire system.

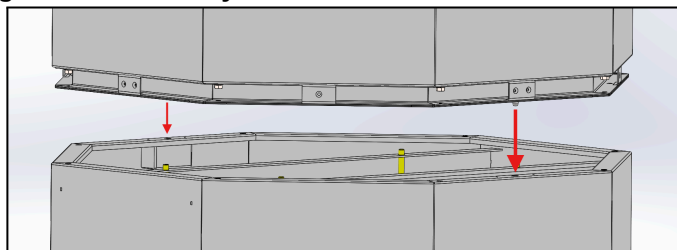
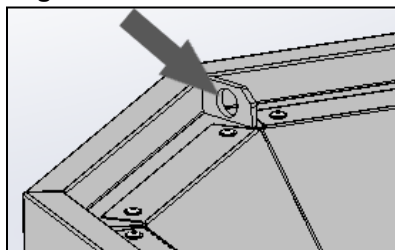

- Upper part and lower part must now be firmly joined together. Use the supplied hexagon head screws to do so.

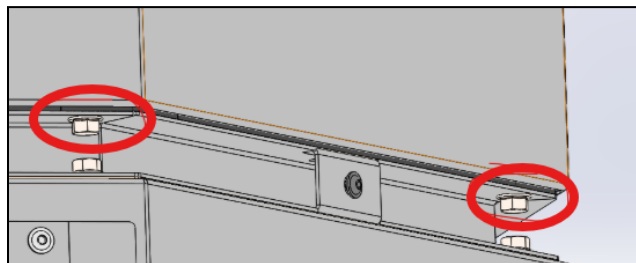

- The panels must be reassembled.

## 5. Commissioning



### WARNING

#### **Dangers arising from a defective condition of the unit.**

Make sure that the measures described in this chapter are completed before the commissioning of the unit. All doors of the unit must be closed and all necessary connections must be attached before turning the unit on. Do not operate the unit if any components are defective, missing or damaged. Check the orderly condition of the unit before switching it on. The unit must not be operated without a filter element.



### NOTICE

#### **Damaged supply lines.**

Make sure that the supply lines are protected against damage by forklift trucks and similar events. Protect all supply lines from heat, moisture, oil and sharp edges.





We recommend adjusting the set time and date of the controller to the local time zone when commissioning the system. The procedure is described in the separate operating manual of the controller.

**A correct time and date is important for analysing the data log, for example.**

## 5.1. Electrical connection

	<b>WARNING</b>
<p><b>Risk of electric shock.</b> Electrical plants and equipment may only be built, modified and maintained by a qualified electrician or under the direction and supervision of a qualified electrician. Do not work on live electrical components and elements if you are not sure that these are indeed disconnected. If necessary, disconnect the device from the mains. The operator is responsible for a potential-free balance of the equipment. Because the unit is equipped with a frequency converter, it may only be operated on networks with an AC/DC sensitive RCCB. The AC/DC sensitive residual current circuit breaker (type B) must tolerate at least a permissible residual current of 100mA. For frequency converter operation, the cross section of the protective conductor</p> <ul style="list-style-type: none"><li>• must be at least 10mm<sup>2</sup>,</li><li>• and must be at least equal to the size of the operator side outer conductor cross-section.</li></ul>	

	<b>CAUTION</b>
<p><b>Health hazard arising from unintentional cleaning processes.</b> Switch on the control only if the unit is in operational condition.</p>	

	<b>NOTICE</b>
<p><b>Electric malfunction possible in cause of an incorrect power supply.</b> Pay attention to the admissible supply voltage. Please observe the specifications on the type plate.</p>	

- Connect the mains cable (see chapter 2.1) to the power supply.

**NOTICE** The 10 metre long mains cable is equipped with a 5-pin 16A CEE coupling plug, protective conductor position 6h.

## 5.2. Coating of the filter cartridges with cartridge protection

For a longer service life of the filter cartridges we recommend to coat them with a cartridge protection. The coating can only be carried out during the commissioning at the operation site. When the operator orders and installs new filter cartridges, we recommend to also coat them before the commissioning.

	<p>Please read and refer to "Coating of new filter cartridges with cartridge protection" in the chapter "Maintenance". There you can also find a description of the operating method of the cartridge protection.</p>
---	---

## 5.3. Connecting the compressed air supply

	<b>NOTICE</b>
<p><b>The compressed air must be dry and oil-free.</b> According to ISO 8573-1:2010 the compressed air quality must at least meet: [7:4:4]</p> <ul style="list-style-type: none"><li>→ Particle size: &lt;math&gt;&lt;40\mu\text{m}&lt;/math&gt;</li><li>→ Pressure dew point: <math>\leq +3^{\circ}\text{C}</math></li><li>→ Oil content: <math>\leq 5\text{mg}/\text{m}^3</math></li></ul>	

### 5.3.1. Compressed air supply for the cleaning of the filter cartridges

The filter cartridges of the system are automatically cleaned. Cleaning is carried out pneumatically via a built-in compressed air tank.

	Without compressed air supply the filter cartridges will become dirty very quickly.
---	---

- The external compressed air supply must be assured with an approved compressed air hose. For the connection to the device, the compressed air hose must be equipped with a quick coupling for an insert sleeve DN 7.2.

**NOTICE** The compressed air must be dry and oil-free. The on-site operating pressure must not exceed 10 bar. Otherwise, there is a risk of material damage.

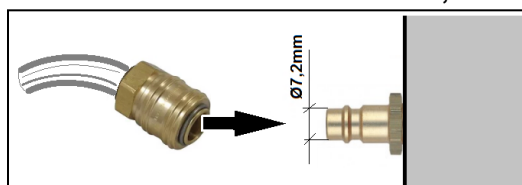

- The operating pressure of the pressure reducer (see chapter 2.1) must be set on a minimum of 3 bars and maximum of 4 bars.



**NOTICE** In case of the pressure being too low, the compressed air tank does not reach quickly enough the operating pressure for the following cleaning. There is a risk of material damage when the pressure is too high.



- Connect the compressed air hose to the insert sleeve (see chapter 2.1).

## 6. Operating the system

### 6.1. Explanation of the operating elements

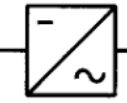
 Control functions, setting options for programs, menu navigation, error messages, etc. are described in the enclosed operating manual of the unit control. There is also an explanation of the elements of the control panel.

Operating elements for the device control		
Representation	Designation	Description / function
	Main switch	<ul style="list-style-type: none"> <li>• <b>OFF:</b> The device is disconnected from the power supply.</li> <li>• <b>ON:</b> The device is connected to the power supply and ready to operate.</li> </ul> <p> <b>The main switch is located behind the service door for the disposable dust collecting tank (see chapter 2.1.)</b></p>
	Frequency converter	The unit is equipped with a frequency inverter that has already been preset ex works. If possible, do not make any changes. Otherwise, contact the manufacturer.

Operating elements for status and error messages		
Representation	Designation	Description / function
	Signal horn	<p>Honking signals that the unit signals a warning or an error. Please refer to the error message shown on the display of the control.</p> <p> <b>Acknowledging or rectifying the malfunction switches the signal horn off again.</b></p> <ul style="list-style-type: none"> <li>&gt; <b>Warning:</b> Signal horn beeps at short intervals.</li> <li>&gt; <b>Malfunction:</b> Signal horn beeps persistently</li> </ul> <p> <b>The display shows a symbol that can be used to mute the signal horn beforehand.</b></p>

## 6.2. Connection of an external control

There is the possibility to control the unit from extern. For this purpose, a connection is provided on the unit (see chapter 2.1).

Connection plug type:	<b>4-pin, M12 socket, A-coded</b>
Number of pins:	<b>4</b>

Pin-Nr.	Designation	Explanation
<b>1, 2</b>	Start contact	In order to switch on the filter unit, a contact has to be connected between pin 1 and pin 2. The unit is switched out when the contact is opened.
<b>3, 4</b>	External message "Fault"	Pin serves for the evaluation of an fault indication.  An internal relay is located behind pin 3 and 4. In a failure-free state, the relay is closed, in case of a malfunction it is open

**NOTICE** The external controller must be connected to the socket marked "External". When connecting it to the connection marked "Modbus", there is a risk of material damage.

**NOTICE** The plug at the socket marked "Modbus" must not be dismantled. Dismantling it could lead to internal communication faults.

## 6.3. Access to the OctaVent through external end devices

Access is possible in a number of ways. These are described in detail in the chapter "Network functions" of the separate operating instructions for the controller.

## 6.4. Connecting to the OctaVents's WiFi



A quick and easy connection of one of your end devices (e.g. PC or laptop) to the OctaVent is possible via the OctaVent's integrated WiFi. If you prefer to integrate the OctaVent into a network, please refer to the enclosed operating manual of the unit control.

- A 4-digit ID ('XXXX') is indicated on the OctaVent's housing.  
(Every OctaVent has its own ID.)

ID:XXXX

- Look for the OctaVent in the WiFi settings of your end device. The OctaVent must be switched on for this.  
WiFi name (SSID): **TEKA\_OctaVent\_XXXX**
- Select the OctaVent and enter the password:  
WiFi password: **OctaVent24364**  
(Some devices require confirmation when connecting to networks without internet access. Check for notifications.)
- Open an internet browser on your end device.  
Enter the following address in the address bar:  
<http://10.19.95.80:5800>  
Password: 24364

You can also scan the QR-Code instead.  
Password: 24364



- If you experience any connection problems, refresh the website in your browser or try using a different end device.

## 7. Maintenance

In accordance with national regulations, the operator is obliged to carry out repeat and functional tests. Unless otherwise specified by national regulations, we recommend regular visual inspections and functional tests of the device as described in the chapter “Maintenance intervals”.

 You find the chapter “Maintenance intervals” at the end of the document. The general maintenance (visual inspection, etc.) is also explained there.

In the chapter “Maintenance intervals” there is information on the maintenance intervals of the filter elements. But these are only recommendations. Depending on the application (multi-shift operation, dust generation, ...) it may be necessary for the operator to change the maintenance intervals.

In this chapter the maintenance work which is caused by wear caused during operation is described.

	<b>WARNING</b>
	<p><b>Work on the open system entails the risk of electrical shock or accidental restart the system. Both pose a danger to life and limb.</b></p> <p>When cleaning and servicing equipment during the replacement of parts or when changing to another function, set the device to maintenance condition first (see chapter “Reset to maintenance state”).</p> <p>A recommissioning of the device must only occur if it is ensured that the device is functionally equivalent to the original state.</p> <hr/> <p><b>Dangers to life and limb when non-original spare parts are used</b></p> <p>Only original TEKA spare parts must be used.</p>

	<b>CAUTION</b>
	<p><b>Hazards to the respiratory tracts are possible.</b></p> <p>All maintenance work must only be carried out in well-ventilated rooms and while wearing an appropriate respiratory mask! We recommend: respiratory protection half mask DIN EN 141/143 protection level P3. For all maintenance work ensure a cautious handling of filter elements and components in order to avoid whirling up dust.</p>

 The operator is obliged to store and dispose of the collected dust in accordance with national or regional regulations. For all maintenance or cleaning work please refer to the applying environmental regulations. Pollutants and filter elements must be disposed of or stored according to the regulations as well. If you have any doubts, we recommend contacting a disposal contractor in your area.

## 7.1. Reset to maintenance state

- Switch off the unit. Unplug the mains plug. Secure the unit against unauthorized restarting during maintenance.
- Disconnect the compressed air hose of the external compressed air supply from the insert sleeve (see chapter 2.1).
- Empty the compressed air tank by opening the drain valve (see chapter 2.1) with a suitable screwdriver. Minor quantities of condensation water can leak out when opening the drain valve. Close the drain valve when the compressed air tank is entirely empty.  
**CAUTION** When opening the drain valve a jet of compressed air can occur.
- After completion of all maintenance work the unit can be reconnected to the power supply and the external compressed air supply.

## 7.2. Cleaning the filter cartridges

The filter cartridges are reusable filters and can be cleaned. The cleaning of the filter cartridges is automatically carried out.

The degree of pollution of the filter cartridges is electronically monitored. In order to assure the required extraction capacity of the device, the cleaning of the filter cartridges starts automatically when a preset differential pressure value is reached. If the preset differential pressure value is not undercut after the cleaning of the filter cartridges, another cleaning starts. The filter unit remains in operation during the automatic cleaning. The compressed air blast is produced in opposite direction to the intake. The cleaned dust falls downwards in the dust collecting tank.

Depending on the setting of the control unit there can be automatic postcleanings of the filter cartridges even when the unit is switched off.

















When the maximal admissible differential pressure value is reached, the device triggers an alarm (see chapter "description of the control elements"). If despite of the automatic cleaning of the filter cartridge the alarm value is not undercut anymore, the filter cartridge, or alternatively the whole filter unit, must be replaced. (see chapter: "Replacing the filter cartridges" / "Replacing the filter unit").

The differential pressure values in the control unit that initiate a cleaning or a filter alarm are preset values adapted to the filter unit. Please find detailed information concerning the functioning in the enclosed operating instructions of the control unit.

## 7.3. Replacing the filter unit

Replacing the filter unit becomes necessary when the filter cartridges are saturated with dirt in a manner that despite of the cleaning the filter alarm is triggered again at very short intervals or permanently. (The filter alarm is described in chapter "Cleaning the filter cartridges".)

The filter unit (see chapter 2.1.) comprises the filter housing including 4 installed filter cartridges.

	<b>CAUTION</b>				
<p><b>Whirling up dust is possible due to the polluted filter cartridges. Danger of unintentional automatic cleaning with the unit switched off.</b></p>					
<p>The filter cartridges must be cleaned before the filter unit becomes replaced. This is done by carrying out 3 manual cleanings via the unit control (see separate operating instructions). The filter unit must be switched off beforehand but without disconnecting the unit from the power supply. After the cleaning, disconnect the filter unit from the power supply and secure it against being switched on again. After cleaning the filter cartridges wait about 5 minutes.</p>					
<table border="1" style="width: 100%; text-align: center;"> <tr> <td data-bbox="384 884 592 1093">   <b>OFF</b> </td> <td data-bbox="598 884 874 1093">  </td> <td data-bbox="880 884 1145 1093">   </td> <td data-bbox="1152 884 1359 1093">   <b>5 min</b> </td> </tr> </table>		 <b>OFF</b>		 	 <b>5 min</b>
 <b>OFF</b>		 	 <b>5 min</b>		

	<b>WARNING</b>
<p><b>Dangers to life and limb when non-original spare parts are used</b>          Only original TEKA spare parts must be used.</p>	

<b>i</b>	<p>We recommend to coat new filter cartridges with cartridge protection before the first commissioning. Refer to the chapter "Coating of new filter cartridges with cartridge protection".</p>
----------	--

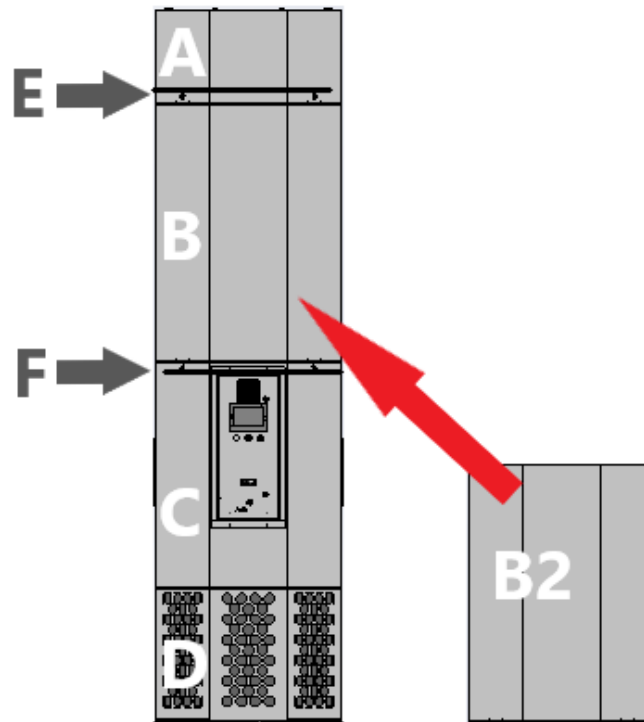

- Position the new filter unit (B2) next to the system. The illustrated side must be at the top. A so-called round sling can be attached around the 2 struts for erecting and lifting purposes.

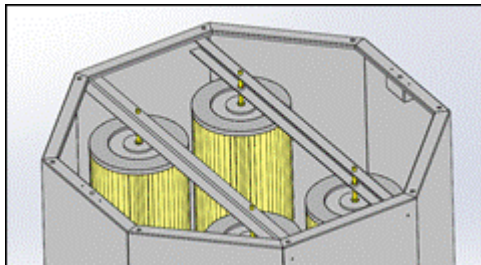

- Check whether the sealing surfaces (top and bottom) of the new filter unit are clean and undamaged.
- Dismantle the 4 panels of the suction housing (A) by releasing the M6x12 rounded head screws. Keep the panels and screws in a safe place for later reassembly.

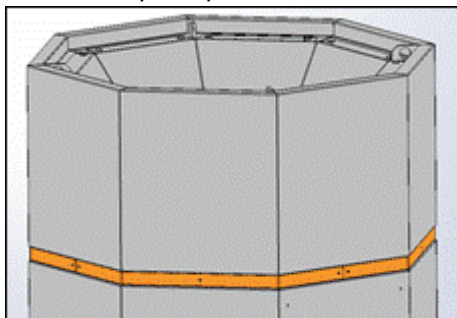

- Then release the 8 hexagon head screws at the joining point between intermediate frame ↔ filter housing. Keep the screws in a safe place for later assembly.

**NOTICE** The intermediate frame (E) must remain on the suction housing (A).

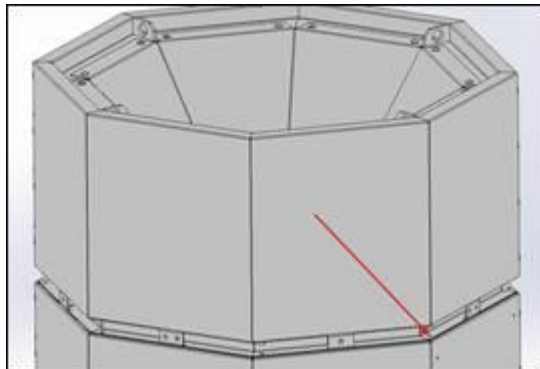

- Lift the suction housing (A) together with the intermediate frame (E) from the old filter unit (B) and place it onto the new filter unit (B2). Check whether the sealing surface (bottom) of the intermediate frame (E) is clean and undamaged. Use the 4 lifting rings to do so. At the same time, align the suction housing so that its 2 guide pins are located above the 2 mounting holes of the filter unit and can be inserted into each other.

Also check whether the seal of the suction housing is undamaged.

**⚠ WARNING** Use appropriate lifting tools (forklift truck, transport crane,...) with a minimum load-carrying capacity of 500 kg. The filter unit must be secured against tilting and slipping when it is moved, lifted or put down. No one is allowed to stand under or beside the load. Use only appropriate ladder tools.

**⚠ WARNING** The lifting rings must only be used to lift the upper part. The lifting rings are not suited to lift the weight of the entire system.

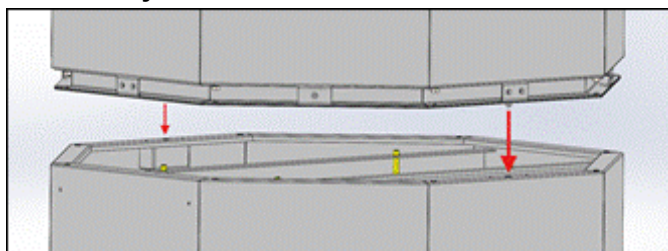
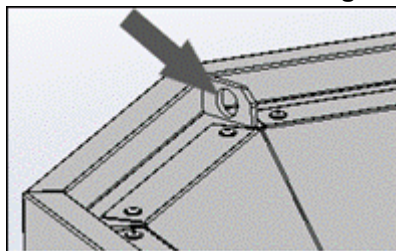

- Firmly screw together the suction housing and the new filter unit (B2). Use the previously dismantled M8x12 hexagon head screws for this. Then also reattach the 4 panels. Use the previously dismantled M6x12 rounded head screws for this.

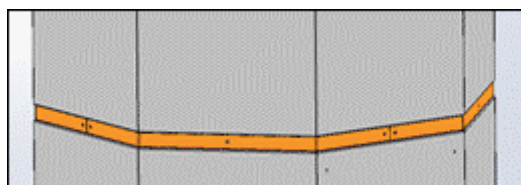

- Dismantle the 4 panels of the dust collecting housing (C) by releasing the M6x12 rounded head screws. Keep the panels and screws in a safe place for later reassembly.

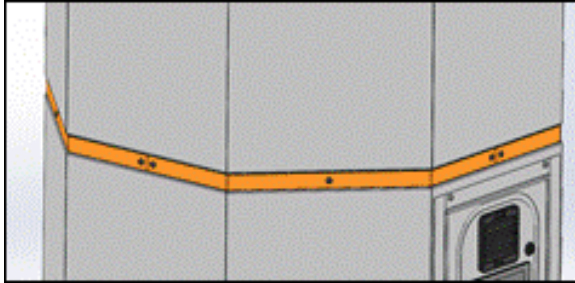

- Then release the 8 hexagon head screws at the joining point between intermediate frame ↔ filter housing. Keep the screws in a safe place for later reassembly.

**NOTICE** The intermediate frame (F) must remain on the dust collecting housing (C).

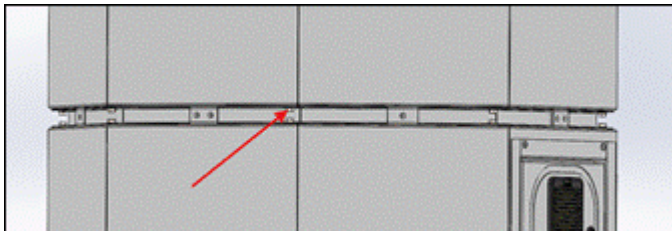

- Now lift the old filter unit (B) off the dust collecting housing. A so-called round sling can be attached around the 2 upper struts for lifting purposes..

**i** The operating company is obliged to store and dispose of the filter unit in its entirety according to national or regional regulations.

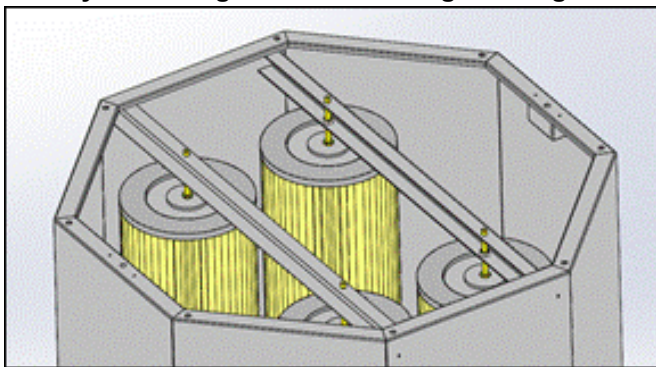

- Check whether the seal of the dust collecting housing is undamaged.
- Now lift the upper part (A + B2) onto the lower part (C + D). Use the 4 lifting rings to do so. At the same time, align the upper part so that the 2 mounting holes are located above the 2 guide pins of the dust collecting housing and can be inserted into each other.

**⚠WARNING** The lifting rings must only be used to lift the upper part. The lifting rings

are not suited to lift the weight of the entire system.

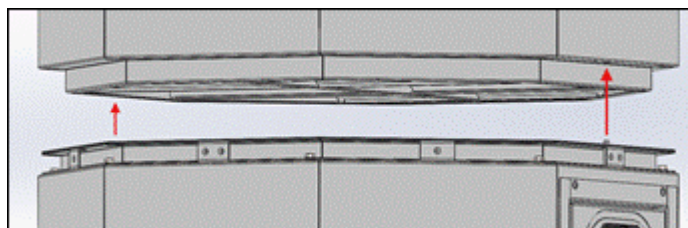
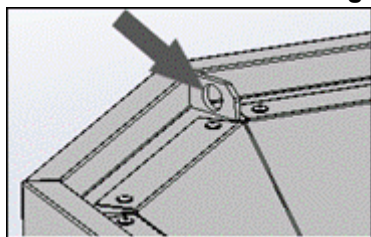



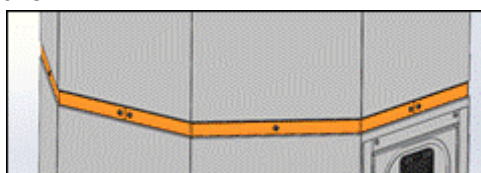













- Firmly screw together the upper part and the lower part. Use the previously dismantled M8x12 hexagon head screws for this. Then also reattach the 4 panels. Use the previously dismantled M6x12 rounded head screws for this.



## 7.4. Replacing the filter cartridges



Replacing the filter cartridges becomes necessary when the filter cartridges are saturated with dirt in a manner that despite of the cleaning the filter alarm is triggered again at very short intervals or permanently. (The filter alarm is described in chapter "Cleaning the filter cartridges".)





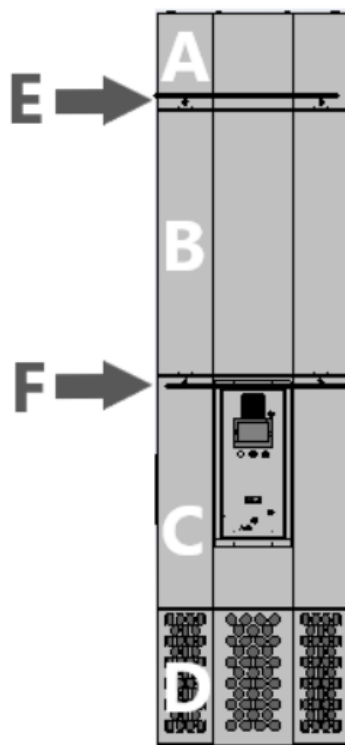

	<b>CAUTION</b>				
<p><b>Whirling up dust is possible due to the polluted filter cartridges. Danger of unintentional automatic cleaning with the unit switched off.</b></p> <p>The filter cartridges must be cleaned before being replaced. This is done by carrying out 3 manual cleanings via the unit control (see separate operating instructions). The filter unit must be switched off beforehand but without disconnecting the unit from the power supply. After the cleaning, disconnect the filter unit from the power supply and secure it against being switched on again. After cleaning the filter cartridges wait about 5 minutes.</p>					
<table border="1" style="width: 100%; text-align: center;"> <tr> <td data-bbox="383 828 590 1030">   <b>OFF</b> </td> <td data-bbox="598 828 869 1030">  </td> <td data-bbox="877 828 1141 1030">   </td> <td data-bbox="1149 828 1356 1030">   <b>5 min</b> </td> </tr> </table>		 <b>OFF</b>		 	 <b>5 min</b>
 <b>OFF</b>		 	 <b>5 min</b>		

	<b>WARNING</b>
<p><b>Dangers to life and limb when non-original spare parts are used</b>          Only original TEKA spare parts must be used.</p>	

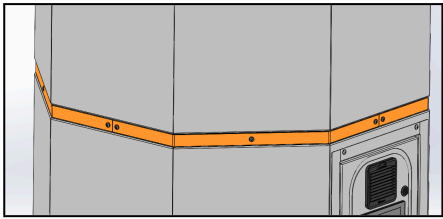
<b>i</b>	<p>We recommend to coat new filter cartridges with cartridge protection before the first commissioning. Refer to the chapter "Coating of new filter cartridges with cartridge protection".</p>
----------	--

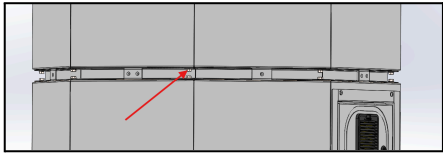

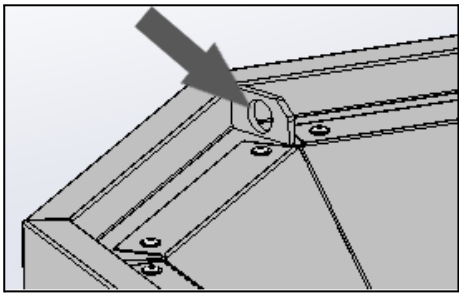
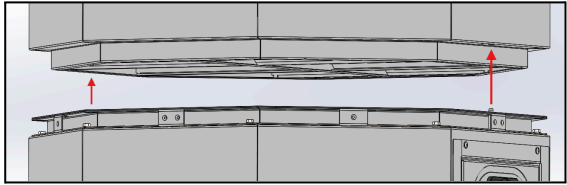
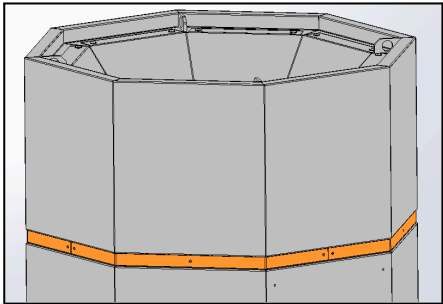
<ul style="list-style-type: none"> <li>• We recommend that two people work together to replace the filter cartridges.</li> <li>• We recommend spreading out a protective film in order to keep the area around the unit clean.</li> </ul>	
<ul style="list-style-type: none"> <li>• <b>CAUTION</b> The filter cartridges may only be replaced in well-ventilated rooms and while wearing an appropriate respiratory mask! We recommend: Respiratory protection half mask DIN EN 141/143 protection level P3.</li> <li>• We also recommend using additional protective clothing such as gloves, disposable overalls and protective eyewear.</li> </ul>	
<ul style="list-style-type: none"> <li>• Make available an original disposal bag already before changing the filter cartridges (see sparts list). We recommend to stock up disposal bags in good time.</li> </ul>	

<ul style="list-style-type: none"> <li>• Dismantle the 4 panels of the dust collecting housing (C) by releasing the M6x12 rounded head screws. Keep the panels and screws in a safe place for later reassembly.</li> </ul>	 <p style="text-align: center;"><b>4</b> </p>
<ul style="list-style-type: none"> <li>• Then release the 8 hexagon head screws at the joining point between intermediate frame ↔ filter housing. Keep the screws in a safe place for later reassembly.</li> </ul> <p><b>NOTICE</b> The intermediate frame (F) must remain on the dust collecting housing (C).</p>	 <p style="text-align: right;"><b>13</b></p> <p style="text-align: center;"></p>
<ul style="list-style-type: none"> <li>• Now lift the upper part (A + B) off the lower part (C + D). Use the 4 lifting rings to do so. Place the upper part next to the system.</li> </ul> <p><b>WARNING</b> Use appropriate lifting tools (forklift truck, transport crane,...) with a minimum load-carrying capacity of 500 kg. The filter unit must be secured against tilting and slipping when it is moved, lifted or put down. No one is allowed to stand under or beside the load. Use only appropriate ladder tools.</p> <p><b>WARNING</b> The lifting rings must only be used for lifting the upper part. The lifting rings are not suited to lift the weight of the entire system.</p>	 
<ul style="list-style-type: none"> <li>• Dismantle the 4 panels of the suction housing (A) by releasing the M6x12 rounded head screws. Keep the panels and screws in a safe place for later reassembly.</li> </ul>	 <p style="text-align: center;"><b>4</b> </p>

- Then release the 8 hexagon head screws at the joining point between intermediate frame ↔ filter housing. Keep the screws in a safe place for later reassembly.

**NOTICE** The intermediate frame (E) must remain on the suction housing (A).

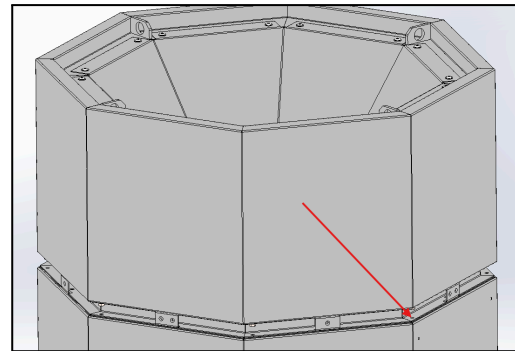

13

- Lift the suction housing (A) off the filter unit (B) and place it next to the filter unit (B). Use the 4 lifting rings to do so.

**NOTICE** Be sure not to damage the two guide pins when setting down the suction housing.

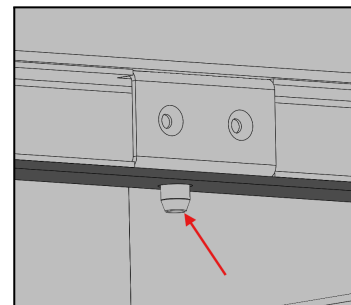
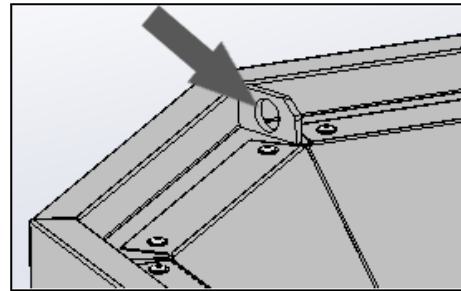

- Release the M10 hexagon nut and thread the rotary plate upwards as far as it will go.

**WARNING** Only suitable climbing aids must be used to improve accessibility (e.g. a platform ladder).

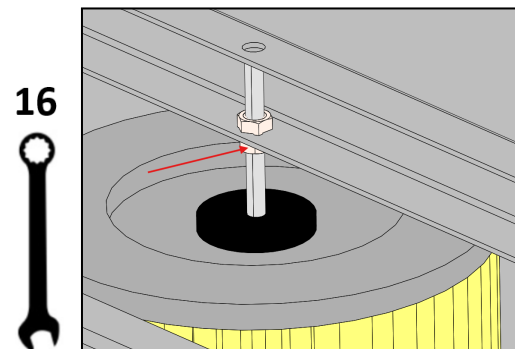

- Pull the disposal bag over the filter cartridge.

- Lift the filter cartridge together with the disposal bag somewhat, tilt it slightly sideways and then lift it upwards out of the housing between housing wall and strut.

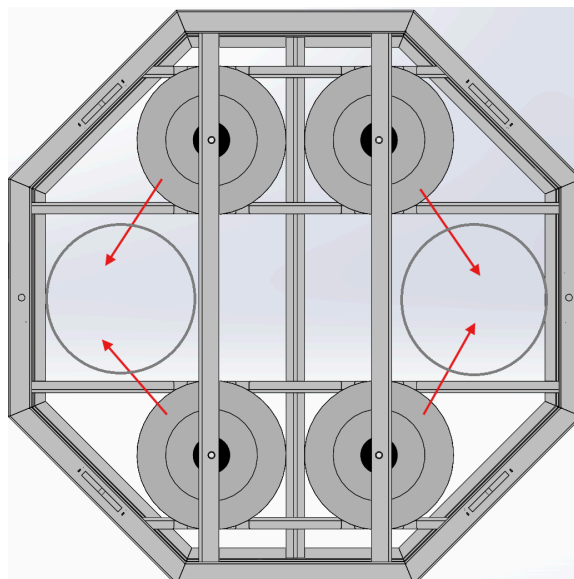

- Seal the disposal bag (e.g. with cable ties).

**i** The operator is obliged to store and dispose of contaminated filter cartridges in accordance with national or regional regulations.

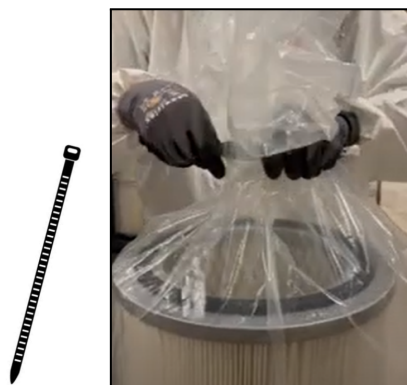

- First of all, remove all the filter cartridges as described in the steps above.

- Only then should you start to install the new filter cartridges.

**NOTICE** Only use TEKA replacement filters. Otherwise the correct functioning of the unit is not guaranteed, and there is a danger to life and limb.

- Insert the filter cartridge into the housing from above through the gap between the housing wall and the strut.

**WARNING** Only suitable climbing aids must be used to improve accessibility (e.g. a platform ladder).

**CAUTION** Ensure the sealing surface of the filter cartridge is seated centrally in relation to the sealing surface of the filter housing.

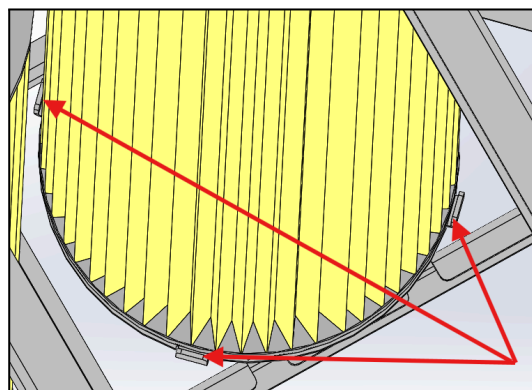

<ul style="list-style-type: none"> <li>• Thread the rotary plate downward as far as it will go to ensure a firm seat of the filter cartridge. Secure the rotary plate against accidental loosening with the hexagon nut M10.</li> </ul>	
<ul style="list-style-type: none"> <li>• Check whether the seal of the filter housing is undamaged.</li> </ul>	
<ul style="list-style-type: none"> <li>• Lift the suction housing (A) onto the filter housing (B). Use the 4 lifting rings to do so. At the same time, align the suction housing so that its 2 guide pins are located above the 2 mounting holes of the filter housing and can be inserted into each other.</li> </ul> <p><b>⚠ WARNING</b> The lifting rings must only be used for lifting the upper part. The lifting rings are not suited to lift the weight of the entire system.</p>	
<ul style="list-style-type: none"> <li>• Firmly screw together the suction housing and the filter unit (B). Use the previously dismantled M8x12 hexagon head screws for this.</li> <li>• Then also reattach the 4 panels. Use the previously dismantled M6x12 rounded head screws for this.</li> </ul>	
<ul style="list-style-type: none"> <li>• Check whether the seals of the dust collecting housing are undamaged.</li> </ul>	

- Now lift the upper part (A + B) onto the lower part (C + D). Use the 4 lifting rings to do so. At the same time, align the upper part so that the 2 mounting holes are located above the 2 guide pins of the dust collecting housing and can be inserted into each other.

**⚠ WARNING** The lifting rings must only be used for lifting the upper part. The lifting rings are not suited to lift the weight of the entire system.

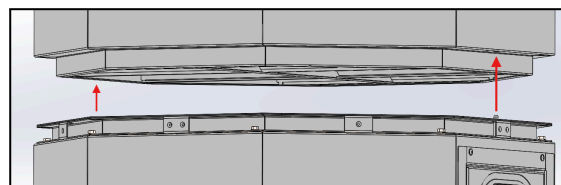
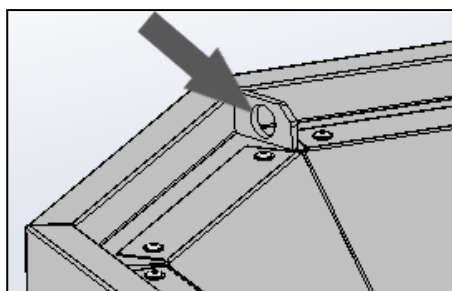

- Firmly screw together the upper part and the lower part. Use the previously dismantled M8x12 hexagon head screws for this.
- Then also reattach the 4 panels. Use the previously dismantled M6x12 rounded head screws for this.

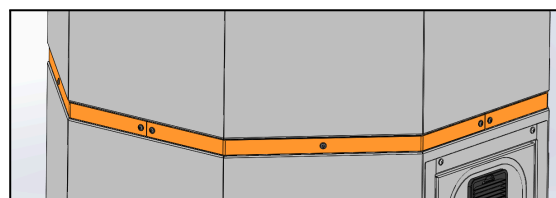

## 7.5. Checking the fill level or replacing the disposable dust collecting tank



### CAUTION

**It is possible that dust is swirled up.**

The dust collecting tank is a disposable tank. Do not try to clean the tank or reuse it. When it is filled, the dust collecting tank must be closed with the lid and disposed of in its entirety, including the dust.

As time progresses, the disposable dust collecting tank (see chapter 2.1) is increasingly filled with dust and must eventually be replaced with a new dust collecting tank. If the process dust in the dust collecting tank has reached the maximum fill level of 80%, the disposable tank must be replaced. We recommend checking the fill level at least once a week.



Make available a new disposable dust collecting tank already before a replacement is necessary. Disposable dust collecting tanks are optionally available from TEKA, see list of spare parts. We recommend stocking up with dust collecting tanks in good time.

For checking or replacing proceed as follows:

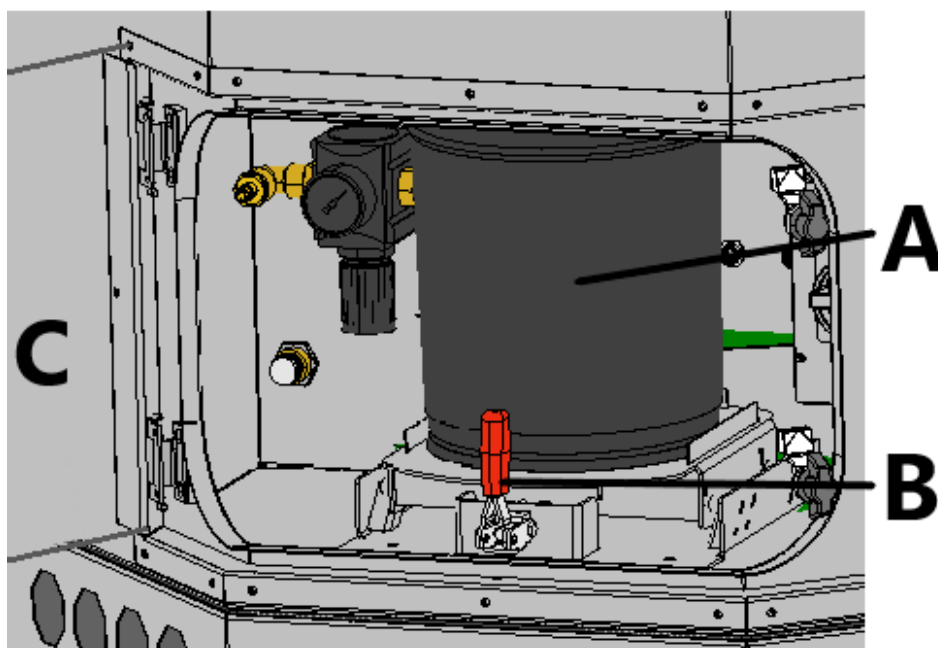

- Open the service door of the dust collecting housing (see chapter 2.1).
- Release the clamping lever (B) of the dust collecting tank (A).
- Carefully pull the dust collecting tank out of the housing.
- Now check the fill level. If necessary, the dust collecting tank must be replaced.
- Check the sealing mat for possible damage. If necessary, replace the sealing mat with a new one.
- Changing the disposable dust collecting tank:  
Close the dust collecting tank with the lid that is inserted in a retaining bracket (C) on the inside

of the service door. Use the tension ring lock of the lid to do so.

Remove the lid of the new dust collecting tank. Place the lid including the tension ring lock into the retaining bracket on the service door.

- Push the new dust collecting tank back into the dust collecting housing.
- Manipulate the clamping lever so that the dust collection container is pressed tightly against the superjacent sealing mat.
- Close the service door.

## 7.6. Draining the condensate

Operation with compressed air can result in condensation water being gradually deposited in the compressed air tank. The condensed water must be emptied regularly. The maintenance interval depends heavily on the quality of the compressed air and cannot, therefore, be determined in advance.

	<b>CAUTION</b>
<b>When opening the drain valve a blast of compressed air is possible.</b> Open the drain valve slowly.	

- Open the service door of the dust collecting housing (see chapter 2.1).
- Empty the compressed air tank by opening the drain valve (see chapter 2.1) with a suitable screwdriver. Let the escaping condensate flow into a suitable container.



- Close the drain valve.

## 7.7. Replacing the activated carbon filter mats

The activated carbon absorbs gases and unpleasant odours. The activated carbon has to be replaced as soon as gases appear on the clean air side.

However, at the latest when the main filter of the device is replaced, the activated carbon should be replaced as well. All 8 activated carbon filter mats must be replaced at the same time.



The saturation degree of the activated carbon is not monitored.

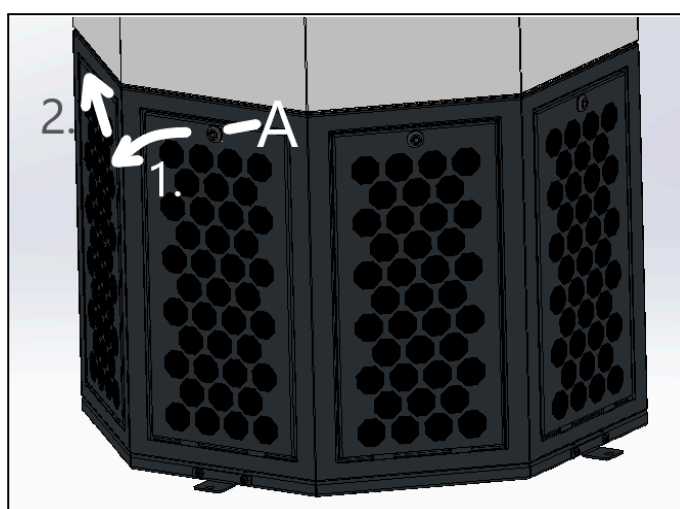

- Release one of the discharge grilles. Loosen its fastener (A) anticlockwise to do so. Pivot the top of the discharge grille slightly forward (1.) to be able to remove it (2.).



- Replace the spent activated carbon filter mat with a new one.  
**NOTICE** Only use TEKA spare filters. Otherwise the proper functioning of the unit is not guaranteed, and there is a danger to life and limb.
- Hook in the discharge grille and fasten it by turning the fastener (A) clockwise to lock it.



- Repeat the procedure for the other 7 activated carbon filter mats.

## 7.8. Replacing the filter mats for the air outlet grille

The filter mat is located in the ventilation grille of the control cabinet. The filter mat must be checked regularly and changed if necessary. This check depends on the degree of contamination. We recommend to stock with filter mats early on (see spare parts list).

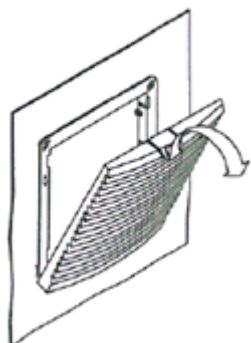

## 7.9. Changing the air quality sensor

The air quality sensor monitors the ambient air. Contaminations in the air can lead to failure of the air quality sensor in the long term. To prevent failures, we recommend to change the air quality sensor (see spare parts list) at regular intervals.

The change interval depends on the accumulating dust quantity and can therefore not be determined beforehand. In one-shift operation we recommend to change the air quality sensor once a year.

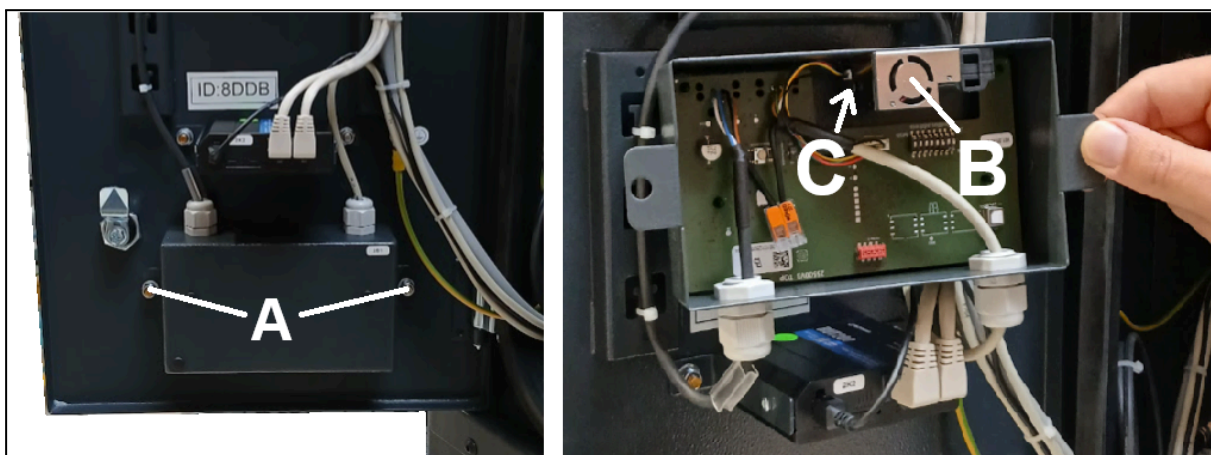

- Open the service door to the control elements (see chapter 2.1.).
- Release the 2 lock nuts (A) of the sensor housing on the inside of the service door.
- Carefully pull the sensor (B) out of the housing.
- Unfasten the cable (C) by gently pulling it off the sensor.
- Insert the cable into the new sensor.
- Carefully slide the new sensor in position.
- Screw together the sensor housing with the 2 lock nuts.

**NOTICE** At the same time, their 2 contact washers must also be re-installed.





- Close the service door to the control elements.
- As soon as the device has been put back into operation, check whether the air quality sensor functions properly. Check whether changing measurements are shown on the display.

**i** After the device is switched on, it takes approx. 3 minutes for reliable measurement values to be displayed.

## 7.10. Coating of new filter cartridges with cartridge protection

Before the first commissioning new filter cartridges can be coated with cartridge protection. The cartridge protection assists against a "caking" of extracted particles on the filter surface and thus prolongs the life of the new filter cartridge.

Unlike with other maintenance work, this step must be carried out with the system switched on and operating. This is necessary to allow the cartridge protection to disperse on the surface of the filter cartridges through suction.

	<b>CAUTION</b>	
	<p><b>On contact the cartridge protection can be hazardous to the respiratory tract and cause skin irritation or eye irritation. Only use TEKA cartridge protection. Non-compliance can result in dangers to life and limb.</b></p> <p>Observe the listed manufacturer instructions provided:</p> <p><i>Handling:</i> Avoid the formation of dust!  <i>Storage:</i> Seal the container tightly before storage!  <i>Respiratory protect:</i> Dust mask without protection level!  <i>Hand protection:</i> Protective gloves in cloth, rubber or leather!  <i>Eye protection:</i> Safety glasses with side shields!  <i>Body protection:</i> Anti-static work shoes!</p>	

	<b>CAUTION</b>
	<p><b>During operation of the device an automatic cleaning can take place. This involves the risk of a sudden jet of high-pressure air and excessive dust formation at the point of entry of the cartridge protection.</b></p> <p>At first make sure that there is no compressed air in the compressed air tank. Please refer to the chapter "Reset to factory settings". Before switching the device back on, disconnect the compressed air hose from the device.</p>

- Provide sufficient cartridge protection. We recommend using **10 grams** for each **square metre** of the **filter surface**. The cartridge protection is available at TEKA (see list of spare parts).
- Switch the device on.
- Let the cartridge protection bit by bit be sucked in from above the suction housing (see chapter 2.1.).

**CAUTION** Risk of falling due to working at heights. Use only suitable ladder tools.

## 8. Dismantling / Disposal

Only authorised personnel may disassemble the machine.

	<b>WARNING</b>
	<p><b>Dangers arising from electricity.</b> Before the dismantling of the machine it has to be disconnected from the power supply and all supply lines.</p>

	<b>CAUTION</b>
	<p><b>Whirling up dust is possible due to the deposited dust.</b> During all work a suitable respiratory protection and protective clothing have to be worn.</p>

	The operator is obliged to store and dispose of the collected dust in accordance with national or regional regulations.
---	---

## 9. Diagnostics and troubleshooting

A list of possible system errors is provided in the table.

	Error messages of the control unit are described in the enclosed operating manual of the control unit.
	Faults indicated by control elements are explained in the chapter "Description of the control elements".

A recommissioning of the device must only occur if it is ensured that the system is functionally equivalent to the original state. Repairs may only be carried out by TEKA personnel or, after consultation with TEKA, by the personnel authorised by the operator.

Adhere to the instructions in the chapter "Safety instructions" and "Maintenance" when carrying out any repairs. If in doubt, contact our TEKA service department:

Tel: +49 2541-84841-0  
E-mail: [info@teka.eu](mailto:info@teka.eu)

Fault	Cause	Removal
System does not start.	Plug power supply is missing or incorrectly inserted.	Plug connector check power supply / plug in correctly.
	No power at outlet.	Check the mains, remove error if possible.

Fault	Cause	Removal
Dust at the dust collecting tank.	There is too much dust in the dust collection container.	Empty the dust collecting tank.
	The clamping lever has not been lift up.	Lift up the clamping lever.
	The seal of the dust collecting tank is damaged.	The seal must be replaced.
	The compressed air for the dedusting is set too high.	Reduce the compressed air.
Dust at the connection point of the housings	The seal between the housings is damaged.	The hinge must be reoriented or replaced.
Suction power too low (smoke hardly extracted).	Filter element is saturated.	Replace the filter package, dispose of old filter properly!
	Filter elements are saturated because no compressed air is connected.	Connect compressed air.
	Suction line contracted.	Check and fix.
	Exhaust line contracted.	Check and fix.
Implausible / permanently consistent measurement values	The device has just been switched on.	After the device is switched on, it takes approx. 3 minutes for reliable measurement values to be displayed.
	Sensor may be defective.	Replace the air quality sensor.

## 10. List of spare parts

Please include the machine number with every order or inquiry.

	<b>WARNING</b>
<b>Dangers to life and limb when non-original spare parts are used.</b> Only original TEKA spare parts must be used.	

Filter element	Article no.
Complete filter unit, inclusively 4 filter cartridges (1000 x 1000 x 1370 mm)	95202001
Filter cartridge, Type "easy clean nano", 20m <sup>2</sup> (Ø260 x 1200 mm) <i>(4 pieces of these filter elements are required for the device)</i>	95202007
Set of activated carbon filter mats (8 pieces, 280 x 570 x 20 mm)	95202002
Filter mats for the air outlet grille (10 pieces)	5020007079
Disposal elements	Article no.
PE-bag for the disposal of filter cartridges (4 pieces)	10030251702
Disposable dust collecting tank, including lid and tension ring, 10 litres (Ø230 x 291 mm)	95202003
Sealing mat for disposable dust collecting tank, foam rubber (Ø320 x 3 mm)	95202004
Cartridge protection	Article no.
"NANNOX P50" for filter cartridges, 400g (in a bucket)	68130000400
"NANNOX P50" for filter cartridges, 100g (in a bucket)	68130000100
Other parts	Article no.
Sealing kit for the joining points of the housings, 16 parts, foam rubber	95202008
Air quality sensor	2017014001
Antenna for mobile communication	2017014005
Antenna for Wi-Fi	2017014006

## 11. Technical data

Supply voltage	V	380 - 480
Frequency	Hz	50 / 60
Type of current	Ph	3
Engine power	kW	6,0
Current intake	A	12,0
Air flow volume max.	m³/h	6.600
Negative pressure max.	Pa	3.000
Protection class		IP20
Extraction performance	%	> 99
Width	mm	1.000
Depth	mm	1.000
Height	mm	3.820
Weight	kg	600
Sound pressure level (in the operation point of use)	dB(A)	66,5
Allowed ambient temperature	°C	+5 to +35 (during operations) -10 to +40 (during transport and storage)
Max. temperature of polluted air at the capture point	°C	+50
Allowed max. humidity	%	70 (non-condensing)
Compressed air supply		dry / oil-free
Necessary external pressure	bar	see chapter "Connecting the compressed air supply"
Compressed air consumption	L/min	80

## 12. EC declaration of conformity

according to the Machinery Directive 2006/42/EG, Annex II, 1 A

TEKA Absaug- und Entsorgungstechnologie GmbH

Millenkamp 9, D-48653 Coesfeld

Tel.: +49 2541-84841-0

E-Mail: [info@teka.eu](mailto:info@teka.eu)

Internet: [www.teka.eu](http://www.teka.eu)

Designation of the device: OctaVent

We hereby declare under our sole responsibility that the product mentioned above, from the serial number A26000010011001 resp. P69500010011001 on, conforms to the following directives:

**Machinery directive:** 2006/42/EC

**Electromagnetic compatibility directive:** 2014/30/EU

**Pressure equipment directive:** 2014/68/EU

**RoHS directive:** 2011/65/EU

This declaration will become void if the device is exposed to modifications that are not approved by the manufacturer in written form.

Authorized representative for the technical documentation:

TEKA Absaug- und Entsorgungstechnologie GmbH, Millenkamp 9, D-48653 Coesfeld

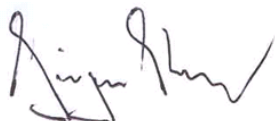

(Jürgen Kemper, managing director)

Coesfeld, 3rd January 2025



## 13. Training protocol

Designation of the device: OctaVent

*(This form can be used by the operator to document the training of the employees. Training should be performed by authorized personnel only. Refer to the instructions in Chapter "Safety Instructions")*

By his signature, the employee confirms that he has been instructed regarding the following items:

Instruction	completed
Description of the device	
Operation and application of the device	
Explanation of the safety instructions	
Behavior in case of fire	
Explanation of the operation elements	
Change and dedusting of the filter elements	
Emptying of the dust collecting tank	
Appropriate disposal	
Maintenance works / Maintenance intervals	

Name of the employee (legible)	Signature

Introduction through (legible):	
Signature:	

## 14. Maintenance intervals

### 14.1. Usage-related maintenance

The described maintenances become necessary through the demands of the system operations. The maintenance intervals are recommendations. Depending on the application (multi-shift operation, dust generation, ...) it may make sense for the operator to change the intervals of maintenance, replacing and cleaning.

Maintenance work must always be documented by means of a protocol.

The approach of the maintenance measures is described in chapter "Maintenance".

Maintenance work	Chapter	Maintenance interval	
		recommended by TEKA	determined by the operator
Cleaning the filter cartridges	7.2.	The cleaning of the filter cartridges is automatically carried out by the filter unit and thus is not subject to a maintenance interval.	
Replacing the filter unit	7.3.	The saturation of the filter cartridges is automatically monitored by the filter unit and thus is not subject to a maintenance interval.	
Replacing the filter cartridges	7.4.	The filter unit triggers an alarm when a replacement of the filter cartridges or the filter unit is necessary.	
Check the fill level/replacing the disposal dust collecting tank	7.5.	weekly	
Draining the condensate	7.6.	monthly	
Replacing the activated carbon filter mats (or check the degree of pollution)	7.7.	When odours occur / when replacing the main filter.  After a preset number of operating hours the controller indicates that a change is necessary.  However, the filter elements must be replaced at the latest every six months.	
Check / Replacing the filter mat for the air outlet grille	7.8.	semi-annually	
Changing the air quality sensor	7.9.	annually (in case of one-shift operation)	

## 14.2. General maintenance

The described maintenances are independent from the demands of the system operations.

The operator is obliged to carry out repeated inspections and functional tests according to national regulations. If not otherwise covered by national regulations, the described maintenance intervals must be respected.

Maintenance work must always be documented by means of a protocol.

Maintenance work	Chapter	Maintenance interval
<b>Visual</b> inspection of the device	14.2.1.	weekly
<b>Visual</b> inspection of the pneumatic pipes	14.2.2.	monthly
<b>Functional</b> test of the device	14.2.3.	monthly
<b>Electrical</b> test of the electrical lines and earthing connections	14.2.4.	annually

### 14.2.1. Visual inspection of the device

**Visual inspection:** Observation that there are no visible safety-related defects.

	<b>WARNING</b> <b>Danger arising from the ready to operate condition of the device.</b> Follow the procedure as described in the chapter "Set to maintenance state".
---	--

The following steps must be carried out in the course of the visual inspection:

- Check all electrical earthing connections and cables for visible damages.
- Ensure that all parts are firmly connected.
- Check all connection points of the filter unit for escaping dust.
- Check all metal parts for corrosion or damages / changes of the coating.
- Visual inspection of the control and operating elements as well as the outside running cables for damages.
- Check the dust collecting tank for tightness, check the sealing rubber of the tank.

## 14.2.2. Visual inspection of the pneumatic pipes

**Visual inspection:** Observation that there are no visible safety-related defects.

	<b>WARNING</b>
<b>Danger arising from the ready to operate condition of the device.</b> Follow the procedure as described in the chapter “Set to maintenance state”.	

The following steps must be carried out in the course of the visual inspection:

- Open the service door of the dust collecting housing.
- Carry out a visual inspection of the pneumatic parts.

## 14.2.3. Functional test of the device

	<b>NOTICE</b>
<b>Possible material damage due to faulty condition of the unit.</b> Carry out a visual inspection before the functional test of the device as described in the previous chapters. The work as described in the chapter “Commissioning” must be finished.	

The following steps must be carried out in the course of the functional test:

- Switch on the device.
- Pay attention to failures or error messages of the control unit. Also refer the separated operating manual of the control unit.
- Pay attention to extraneous noises or vibrations during the device’s operation.
- Carry out a manual dedusting of the filter cartridges. Also refer to the separated operating manual of the control unit.
- Check if within one interval of the filter dedusting the number of dedusting shocks is equal to the number of filter cartridges (in each interval successively every filter cartridge becomes dedusted once).
- Check if dust is escaping from the unit during the dedusting cycle.

## 14.2.4. Electrical test of the electrical lines and earthing connections

	<b>WARNING</b>
<b>Danger arising from electricity.</b> The operator is responsible for ensuring that all work on electric components is carried out by authorised and qualified personnel.	

The device is subject to regular electrical checks by the operator of the device, and are subject to national standards of the different countries.

The here recommended maintenance interval complies with the in Germany applying "Regulation 3 of the German Social Accident Insurance - Electrical plants and equipment" (formerly known as BGV-A3).

The check must only be carried out by a qualified electrician or a person trained in electrics using suitable measuring and test devices. The scope of testing and the methods must be in line with the respective national standard. All contacts in the control cabinet must be checked for tight fit, and must be readjusted if necessary.